

## TEST & MAINTENANCE INSTALLATION INSTRUCTIONS

*NOTE: Circuit feeding unit must be protected by lock-on breaker. If breaker feeding this unit does not have a lock-on device – WARRANTY WILL BE VOIDED.*

1. Mount unit in desired location. Keyhole mounting slots are provided on the rear of the cabinet.
2. Connect the battery female connector(s) to the male connector(s) which is on the charger module.
  - Red to Positive (B+).
  - Blue (or black) to Negative (B-).
3. Connection to the AC power line.
  - A. If to be connected to a 120 V, 60 Hz outlet:
    - Plug line cord into outlet, if it's already installed to the unit.
    - See line cord installation instruction, if line cord is in a separate kit.
  - B. If to be hard wired:
    - Turn Off the unswitched AC power supply from the main breaker.
    - Connect AC input to transformer leads as follows:
      - 120VAC operation: WHITE to neutral AC input, BLACK to 120 VAC input wire.
      - 347 VAC operation: WHITE to neutral AC input, RED to 347 VAC input wire.
    - Make sure to cap off the unused (red or black) wire with a wirenut.
    - Turn the AC power back ON.
4. The AC ON pilot light will come on.
5. The high charge pilot light will come on.
6. After the unit has been operating for at least 30 seconds depress test switch. The AC ON pilot light will go out and the emergency lights will come on.
7. All units are equipped with a low voltage battery protection circuit. This "LVD" disconnects the lamp load when the battery is discharged at 80% of its nominal voltage.
8. Building and licensing in many areas of Canada require you to keep records showing you have checked this emergency lighting unit on a regular basis. Using the following guidelines and the space on the reverse side will make this an easy job.

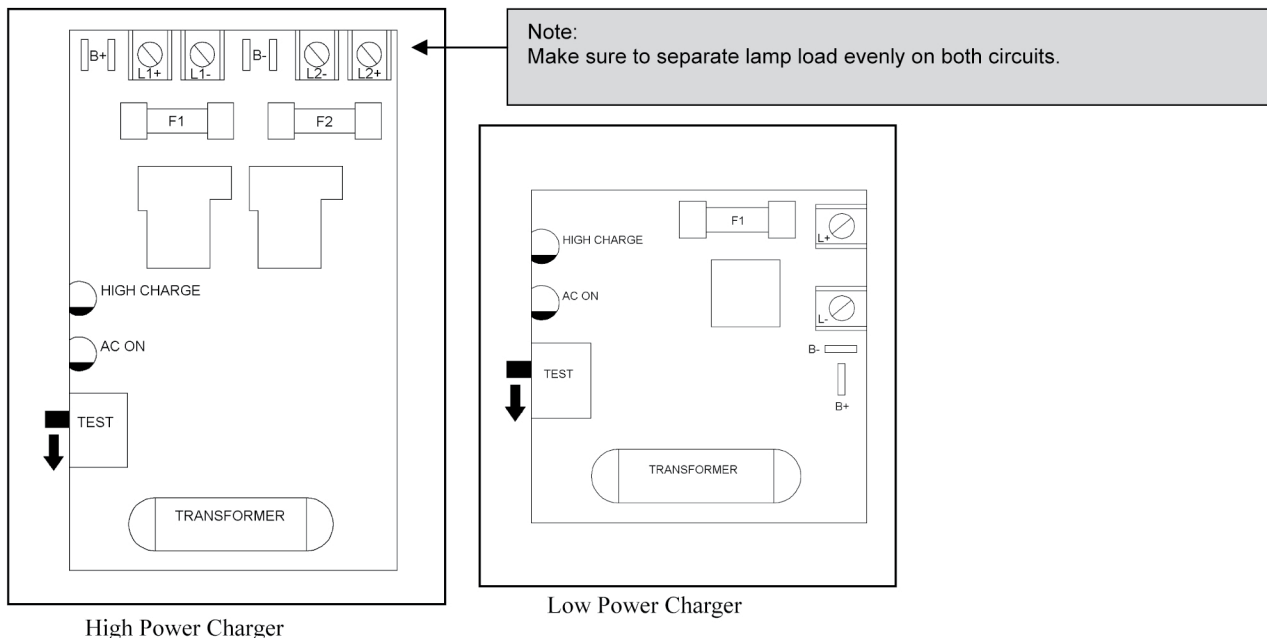

**ALL SERVICING SHOULD BE PERFORMED BY QUALIFIED SERVICE PERSONNEL**

# EMERGI-LITE

## DELIBERATE AC SHUTDOWN

If the AC input power is intentionally turned off for more than 72 hours, disconnect one battery lead to prevent damage to battery. Isolate loose battery lead so that it cannot be inadvertently shorted.

## BATTERY REPLACEMENT

A battery has reached the end of its useful life when it cannot light lamps for full time rating despite normal charger operation. To replace battery, first disconnect AC power to unit, open unit, disconnect battery leads, then remove it and install new battery. Make sure the red lead connected to battery positive is also connected to charger positive (+) terminal.

After unit has been on charge for 24 hours at nominal AC voltage, check that battery voltage is within limits.

Refer to markings on battery or unit model for correct replacement type.

## LAMP REPLACEMENT

It is important to replace burned lamp with a new lamp with the same voltage and wattage. Higher wattage will cause battery to discharge faster (less time) or overload relay. Lower wattage may not provide adequate light output.

## TESTING

Once every 3 months the unit should be checked and then tested for at least 30 seconds by using the test switch or disconnecting the plug or pulling the fuse or breaker. Before testing, the amber pilot light should be on and the red high charge lamp (when supplied) will "wink on" occasionally. After the power has been restored the high charge light will stay on for several minutes then start to "wink" indicating the battery is up to full charge. Once every year the unit should be tested under simulated power failure or electrical fault condition for the time period required by the national Building Code, i.e. 30 m – 1 hr – 2 hrs. After power has been restored, unit will go on high charge for up to 24 hours. If a power failure has occurred recently and the unit worked properly, it is not necessary to perform the simulated failure. Indicate on the charts the date of the failure.

## TEST CHART

Use below chart to record tests.

1. Day of the test
2. Initial of inspector

## CAUTION

The battery in this unit will hold charge until the date shown on the carton. After this date the unit must be plugged in and battery connected to charger for at least 24 hours to recharge battery. Battery shall then be disconnected. Shelf life will then be good for six months before recharging again. If the unit is not placed into service or re-charged by the date shown on the carton, warranty will be void. The AC power supply shall be unswitched, otherwise warranty will be void. This unit is designed to operate between 10°C and 30°C (50°F and 86°F). Operating temperatures outside those limits will void warranty.

TYPE: Sr. No.:					Location:							Full Test	
Date:	J	F	M	A	M	J	J	A	S	O	N		D
20_____													
20_____													
20_____													
20_____													
20_____													
20_____													
20_____													
20_____													
20_____													
20_____													
20_____													

**ALL SERVICING SHOULD BE PERFORMED BY QUALIFIED SERVICE PERSONNEL**